

STRAIGHT SIDE PLATES GALLE CHAINS

Dimensions in mm

STRAIGHT SIDE PLATES - HEAVY DUTY SERIES

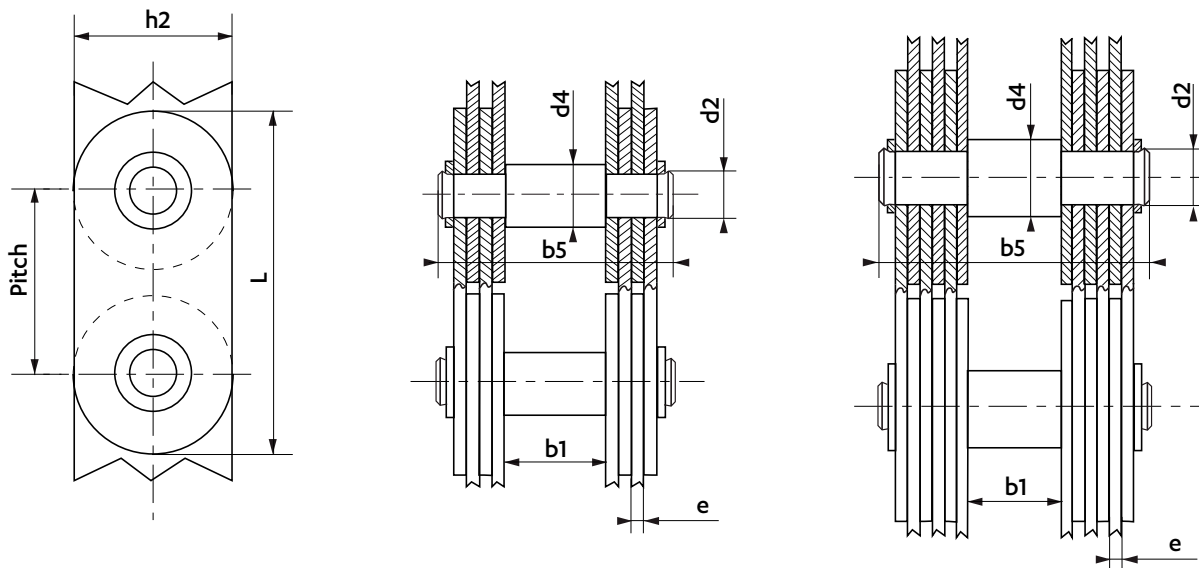

DUPLEX

TRIPLEX

Chain ref	Pitch	BEARING PINS				PLATES			Min. Breaking load kN	Working surface mm <sup>2</sup>	Weight kg/m
		Pin Ø d4	Width between inner plates b1	shouldered pin Ø d2	Width over the pins riveted on washers b5	Height h2	Thickness e	Length L			
<b>DUPLEX</b>											
300	32	12	18	10	57,0	22	3	62	50	107	4,5
301	36	15	20	12	63,5	26	4	70	75	184	7,0
302	43	18	24	15	70,0	32	4	83,5	100	220	9,0
<b>TRIPLEX</b>											
303	50	21	28	18	92,0	38	4	97	150	415	14,0
304	58	24	32	21	97,0	42	4	100	200	490	17,0
305	68	28	35	24	102,0	50	4	129	250	560	21,0
306	82	34	40	29	120,4	60	5	160	375	855	30,0