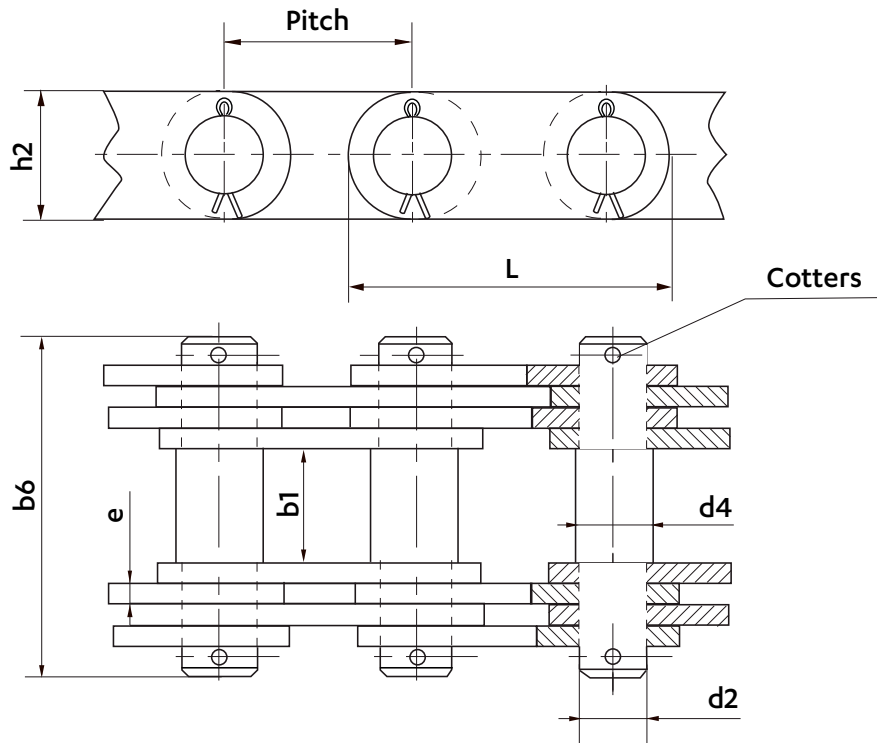

Dimensions in mm

**STRAIGHT SIDE PLATE CHAINS FOR DRAW BENCHES**

Chain ref	Pitch	PINS				PLATES			Breaking load	Working surface	Weight
		Diameter	Width between inner plates	Extended pin Ø	Width over the cotted pins	Thickness	Height	Length			
	P	d4	b1	d2	b6	e	h2	L	kN	mm <sup>2</sup>	kg/m
<b>DUPLEX</b>											
200	50	21	28	18.3	87	5	35	90	150	360	12
201	60	25	35	20.4	105	6	45	107	250	490	18
202	75	32	40	27.2	115	6	60	140	375	650	25
203	85	35	50	30.1	142	8	70	165	500	960	35
204	100	42	60	35.7	173	10	80	190	750	1420	48
205	120	48	70	42.0	204	12	90	225	1000	2010	65
206	150	60	80	53.0	224	12	120	285	1500	2540	85
207	180	68	90	55.0	250	14	140	340	2000	3080	130