

BS STANDARD CHAINS - M140

Dimensions in mm

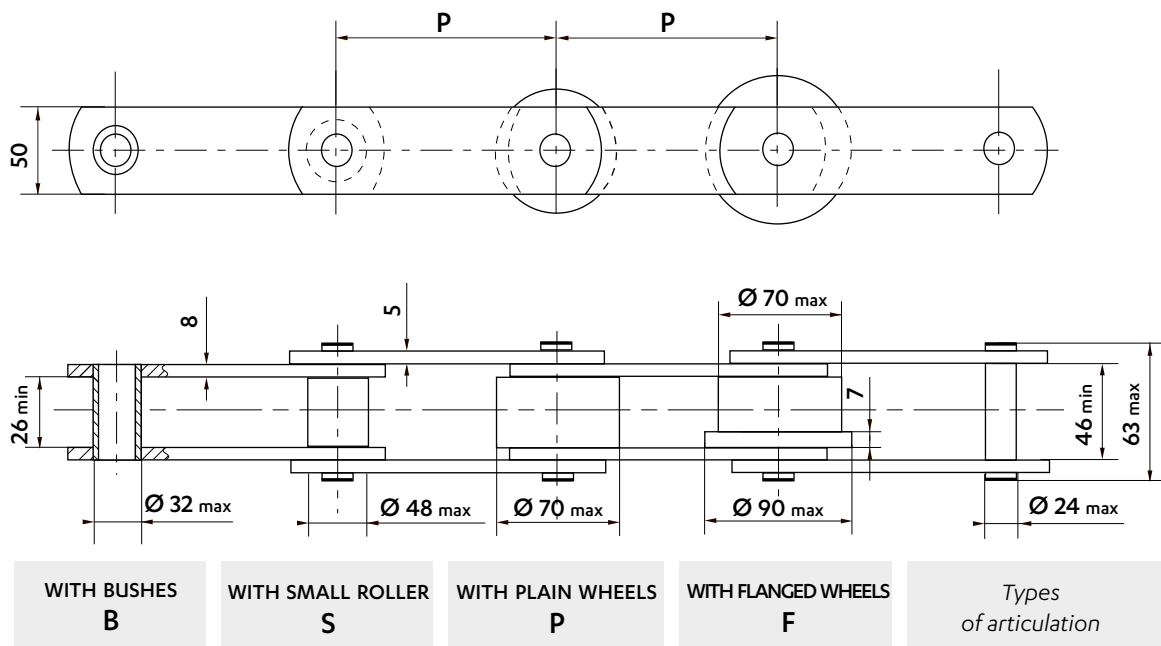

Wheels in different materials can be supplied.

WELDED K1 & K2 ATTACHMENTS - 50 X 50 X 6

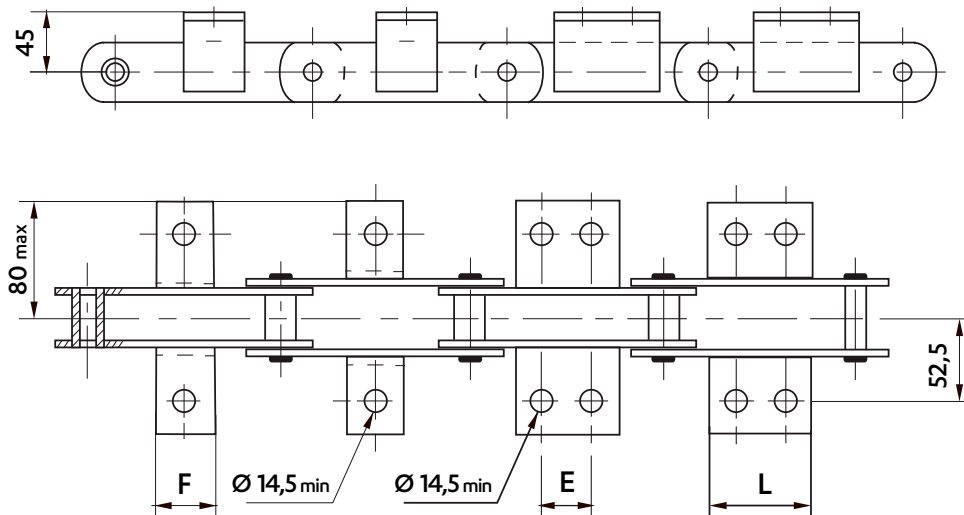

Frequency of attachments on request : on one or both sides of the chain, on inner and/or outer links

Pitch	Attachment dimensions (mm)			Weight of the chain (Kg/m)				Weight of the attachment (Kg/piece)	
	F	E	L	Bush (B)	Roller (S)	Plain wheel (P)	Flanged wheel (F)	K1	K2C
100	50	♦		12,0	13,9	-	-	0,27	-
101,6	50	♦		11,9	13,9	-	-		-
125	50	♦		10,5	12,0	15,2	16,1		-
127	50	♦		10,5	12,0	15,1	16,0		-
150 *	50	60	90	9,5	10,8	13,4	14,2		-
152,4 *	50	60	90	9,5	10,8	13,3	14,1	0,49	-
160	50	60	90	9,4	10,6	13,1	13,8		-
200	50	60	90	8,4	9,4	11,3	11,9		-
203,2	50	60	90	8,4	9,4	11,3	11,8	-	-

Despatch possible within 2 weeks

♦ Not standard : possible to make on request.

\* These pitches allow mounting of K2 attachments only on outer links

Intermediate pitches are on request

Dimensions in mm

## STANDARD CHAIN WHEELS

Sedis wheels are supplied made of machine-welded steel or of cast iron in some cases.

Teeth are raw casting or flame-cut, or machined for bush chains.

Wheels can be supplied bored and keyed.

For wheels with offset hub, the entry point of the key is placed at the same side as the teeth, unless specified otherwise.

We can make on request:

- wheels with machined teeth
- wheels with a different number of teeth
- special wheels

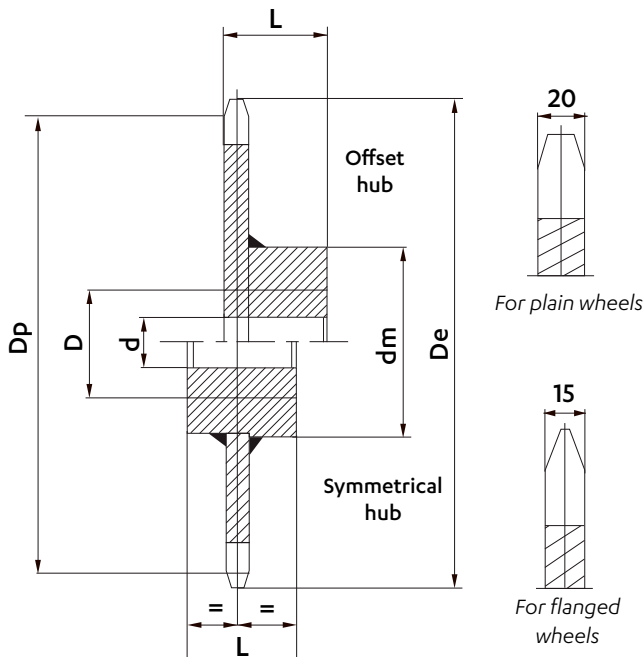

Pitch	Number of teeth	Dimensions (mm)						Weight (kg/p)
		Dp	De	d	D	Dm	L	
100	8	261,31	287	30	90	150	80	18
	10	323,61	349	30	90	150	80	24
	12	386,37	412	30	90	150	80	28
101,6	8	265,49	291	30	90	150	80	18
	10	328,78	354	30	90	150	80	24
	12	392,55	418	30	90	150	80	28
125	8	326,64	352	30	90	151	80	20
	10	404,51	430	30	90	150	80	30
	12	482,96	509	30	90	150	80	40
127	8	331,87	357	30	90	1510	80	20
	10	410,98	437	30	90	150	80	30
	12	490,69	516	30	90	150	80	40
150	8	391,97	418	30	90	150	80	30
	10	485,41	511	30	90	150	80	42
	12	579,56	605	30	90	150	80	55
152,4	8	398,24	424	30	90	150	80	30
	10	493,18	519	30	90	150	80	42
	12	588,83	614	30	90	150	80	55
160	8	418,1	444	30	90	150	80	35
	10	517,77	543	30	90	150	80	50
	12	518,19	644	30	90	150	80	65
200	8	522,63	548	30	90	150	80	45
	10	647,21	673	30	90	150	80	65
	12	772,74	798	30	90	150	80	90
203,2	8	530,99	557	30	90	150	80	45
	10	657,57	683	30	90	150	80	65
	12	785,1	811	30	90	150	80	90

## CONNECTING LINKS

REF N° 208  
Cottered connecting link

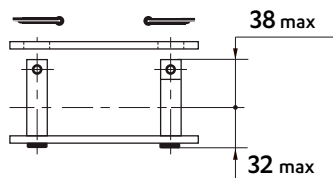

REF N° 209  
Connecting link with self-locking nuts

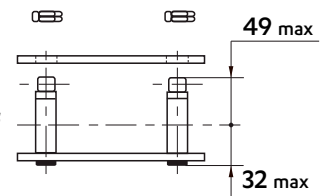

## DRILLED PLATES

On outer and inner plates

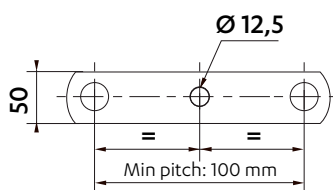

1 HOLE

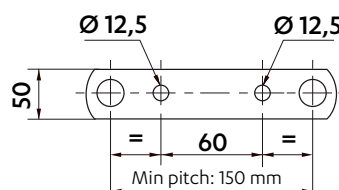

2 HOLES

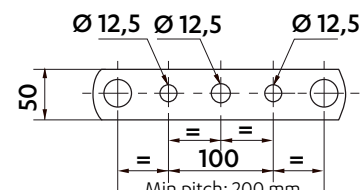

3 HOLES